

## Vertical Machining Center (JN-NV1690)

# Technical Document

By Jiangnan CNC Machine Co., Ltd.

By Jiangnan Technology (Songyang) Co., Ltd.



The picture is for reference only, the actual appearance may vary slightly due to selected configurations.

Party A: :

Party B: Jiangnan CNC Machine Tool Co., Ltd.

Date:

Date:

## 1. Company Profile



Jiangnan CNC Machine Tool Co., Ltd. is located in the beautiful coastal city of Wenzhou, China. It is a CNC machine manufacturing enterprise integrating research, design, manufacturing, and sales. The company was established in September 2006 and currently has a standardized plant covering an area of 85,000 square meters, with more than 180 excellent staff members. Among them, 90 employees have a college degree or above, accounting for 50% of the total staff; the company has 20 research and development personnel, accounting for 9% of the total workforce.

Adhering to the business philosophy of "technological innovation, win-win cooperation, integrity and efficiency, sincere service," and the quality policy of "quality first, customer foremost," the company provides customers with the most cost-effective products and comprehensive services, aiming to create the maximum value for customers. With advanced equipment including the world's most advanced large-scale CNC five-axis machining center and horizontal machining center, as well as contour grinding machines and high-precision Renishaw inspection equipment, the company strictly adheres to international standards. It has obtained ISO9001 certification and implements rigorous process inspections to ensure product quality.

The company mainly manufactures vertical Machining Centers, horizontal Machining Centers, drilling and tapping machine, gantry series, CNC lathes, and other series of products:

1. Vertical Machining Centers: JN-IV850, JN-NV856, JN-NV900, JN-NV1050, JN-IV1160, JN-NV1300, JN-NV1690, etc.
2. Horizontal Machining Centers: JN-H50, JN-IH50, JN-H63, JN-IH63, JN-H800, JN-H1810, etc.
3. Drilling and Tapping Machines: JN-T500, JN-T700, etc.
4. CNC Lathes: JN-CH106, JN-CH108, JN-CH108M, JN-CH108MY, JN-CH208, JN-CH506MSY, etc.
5. Gantry Series: JN-GL2013, JN-GL2015, JN-GL2518, JN-GL2720, JN-GL3023, JN-GL4023, JN-GL4027, JN-GL5030C, etc.

Our machine tools are popular in major provinces and cities in China, including Beijing, Shanghai, Chongqing, Tianjin, Hebei, Henan, Shanxi, Shandong, Jiangsu, Zhejiang, Guangdong, Anhui, Hubei, Fujian, and others, due to their excellent performance and first-class after-sales service. The company adopts a combination of direct sales and distributorship models and has cooperated with 100 distributors nationwide, covering major cities across the country.

Jiangnan CNC – A national brand, a national pride! We sincerely invite you to join with us to create a new era of high-tech machinery!

## 2.Introduction the Songyang Factory



Jiangnan Technology (Songyang) Co., Ltd., a wholly-owned subsidiary of Jiangnan CNC Machine Tool Co., Ltd., was established in August 2017. Located in the beautiful scenic city of



Songyang, Lishui, it covers an area of 107.69 acres with a total construction area of 29,693 square meters. The company has a registered capital of 50 million yuan, with fixed asset investment of 300 million yuan and working capital investment of 70 million yuan. It has introduced multiple sets of high-precision equipment such as the Japanese DAIWA CNC gantry five-axis machining center and horizontal machining centers.

Building on the development foundation of its parent company, Jiangnan Technology actively promotes brand building and product serialization strategies. Internally, it implements ERP systems and information construction, optimizing business processes, and enhancing the company's management level and core competitiveness. Facing the challenges of economic globalization, Jiangnan will continue to focus on the CNC machining center industry, adhere to market-oriented business philosophy, and persist in the direction of "internationalization, technologicalization, and industrialization." It will vigorously introduce advanced equipment, technology, and talents, integrate resources, leverage strengths, and strive to shape "Jiangnan" into a well-known enterprise in the international CNC machining center industry.

### 3. Optical machine diagram

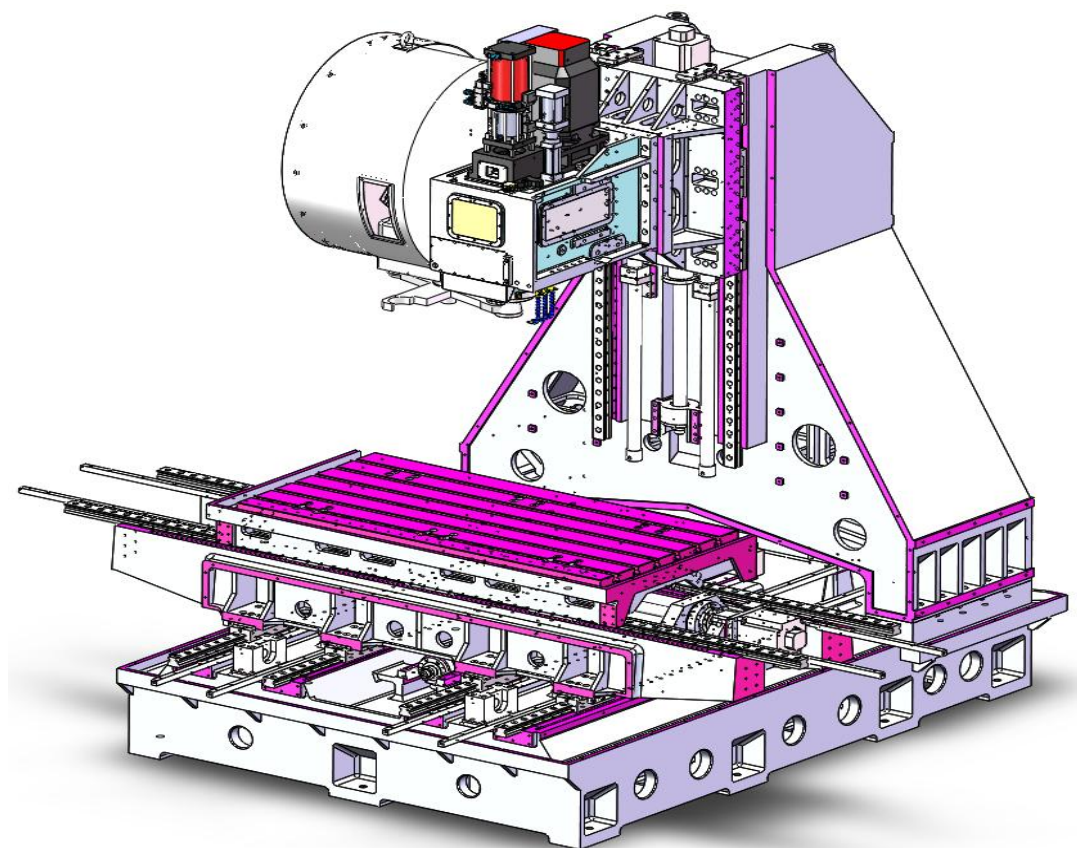

#### 4.The technical parameters of the JN-NV1690

Item		Unit	Specification
Worktable	Table size	mm	1700*850
	Processing range	mm	1600*900
	T-slot	mm	125*22*6
	Table load	kg	1500
Travel	X/Y/Z travel	mm	1600*900*850
	Spindle nose to table surface	mm	150-1000
	Spindle center to column surface	mm	957
Spindle	Spindle taper		BT40
	Spindle drive method		Direct link
Spindle Motor	Spindle motor	kw	15-18.5
Feed Rate	X/Y/Z cutting feed	mm/min	1 ~ 10000
	X/Y/Z rapid feed	m/min	20/20/20
Precision	Positioning accuracy	mm	0.01
	Repeat positioning accuracy	mm	0.006
Automatic Tool Change System	Tool magazine capacity	T	24
	Tool change method		Randomization
	Max. tool diameter	mm	Φ78
	Max. tool diameter (Next to Empty Slot)	mm	Φ150
	Max. tool length	mm	300
	Max. tool weight	kg	8
	Toolholder type(Pocket spec)		BT40
	Tool change time	s	5 (T-T)
Others	Air pressure demand	kg/cm <sup>2</sup>	5-7
	Power requirement	kva	50
	Machine weight	kg	12000

The actual values for power supply, air pressure source, machine weight, and overall dimensions may vary due to different configurations and peripheral equipment.

## 5. Detailed supplier of main components

No.	Name	Manufacturer	Brand Origin	Remarks
1	CNC System	FANUC	Japan	0I-MF
2	Spindle Motor	FANUC	Japan	βI12/12000
3	X/Y/Z Axis	FANUC	Japan	βis30/2000 βis30/2000           β is40B/2000
4	Ballscrew (X/Y/Z Axis)	PMI/ HIWIN	Taiwan	50/50/50
5	Linear Guideway (X/Y/Z Axis)	PMI/ HIWIN	Taiwan	XAxis 2Rail*55 (6) YAxis 4Rail*55 (8Slider) ZAxis 2Rail*55 (6Slider)
6	Ballscrew Coupling	JANETECH	Taiwan	
7	Bearing	NACHI	Japan	
8	Electric Lubrication System	HERG	Joint Venture	
9	Cutting cylinder	HINAKA	Taiwan	
10	Spindle	POSA	Taiwan	
11	Tool Magazine	CHNCIT	China	
12	Cooling Pump	STAIRS	Taiwan	
13	Air Tank		China	
14	Pneumatic Components	SMC	Japan	
15	Transformer		LUHO	
16	Electrical Components	Schneider	France	
17	Telescopic Cover	CHNCIT	China	
18	Rear flush	CHNCIT	China	
19	Machine Peripheral Sheet Metal	CHNCIT	China	
20	Oil cooler	Tongfei	China	

Note: If any supplier fails to supply, it will be replaced with a brand of equal quality without further notice.

## 6. Optional accessories list

No.	Name	Quantity/Unit	Note
1			
2			
3			
4			
5			
6			
7			
8			

## 7.Tools and manuals list

No.	Name	Quantity/Unit	Remarks
1	Toolbox	1Set	
2	Certificate of conformity	1Copy	
3	Machine specification	1Set	
4	Machine specification System specification	1Set	
5	Air gun	1 Piece	

## 8.Machine Mechanical Indicators

### 8.1、 Machine Structure

Machine Structure The main structural components of the machine tool are made of high-tensile cast iron, optimized in design for high static rigidity. The spindle features a high-rigidity structure, high mechanical efficiency, suitable for high-precision heavy cutting machining. The spindle motor adopts AC servo technology, enabling stepless speed regulation in both forward and reverse directions. The three-axis ball screw and servo motor drive directly, with no transmission cumulative error, ensuring high repeatability and positioning accuracy. Automatic tool changing structure, quick and smooth tool changing operation. All machine components and various measurement units comply with international (ISO) standards.

### 8.2、 Machine Protection

Machine Protection The machine protection device is safe, complete, and reliable. Machine noise: in compliance with national standards, 75dB. Electrical control cabinet sealed to prevent dust and water, IP65 rating.

### 8.3、 Lubrication System

Lubrication System Adopts TZ electric lubrication device to quantitatively lubricate all sliding surfaces and ball screws. Adjustable lubrication time intervals and amounts to ensure 100% lubrication at all lubrication points. Machine displays an alarm in case of low oil level (oil shortage). Uses 68# guide rail lubricating oil. Lubrication tank capacity: 2 liters. Lubrication pump voltage: 220V, motor output power: 25W, maximum pressure: 2.5MPa, discharge flow rate: 110ml/min.

### 8.4、 Pneumatic System

Pneumatic System Pneumatic system, pressure switches, solenoid valves, etc., realize pneumatic tool changing, pressure: 6-8KG/C m<sup>2</sup>, flow rate: 220L/MIN, can clean the working area.

### 8.5、 Electrical System



Electrical System The standard system has complete and reliable interlocking, safety protection, and fault self-diagnosis alarm functions. Equipped with RS232 standard communication interface, can use computer floppy disk for program storage.

(According to the requirements of users can provide the corresponding software)

Other systems can be provided according to user requirements.